

# Engineering Data Sheet

6001

## Product: ContamAway II™ High Performance Aqueous Waste Treatment System

The ContamAway II™ units are small flow, multipurpose, medium duty, factory packaged aqueous waste treatment plants that are designed to:

- ◆ Remove free oils/fuels (i.e., insoluble hydrocarbons),
- ◆ Remove gross settleable solids,
- ◆ Remove chemically and mechanically emulsified oils,
- ◆ Remove fine suspended solids (to 1 micron), and
- ◆ Remove volatile and semi-volatile organic compounds, PCBs, pesticides, BOD/COD/TOC, dissolved organics, and heavy metals to near non-detect levels.

### Product Application

In addition to decon water, the unit will successfully treat stormwater runoff, hydroblast waters, detergent based tank and equipment washwaters, ground dewatering liquids, underground storage tank residuals, and contaminated site groundwater. ContamAway II™ units are ideal for contractors, car and truck dealerships, equipment rental yards, machine shops, maintenance facilities, airport terminals, taxi and bus garages, rail yards, and manufacturing companies.

### Product Usage

Routine plant operation is entirely automatic and fail-safe. Improper operation is virtually impossible. Routine maintenance consists of two activities:

1. The replacement of either of two different filter cartridges whenever a strobe warning light starts flashing.
2. The replacement of the tri-media adsorber when the adsorptive capacity has been reached as determined by periodic sampling and testing.

Suspended solids are removed using two stages of treatment to maximize the run time between operator servicing. For most applications, the filter cartridges and adsorber units should last for several months before requiring change out. WaterSmart Environmental, Inc. stocks the replacement items in inventory for overnight shipment, if necessary.

The ContamAway II™ treatment process requires absolutely no chemicals for either heavy metals removal or for system disinfection. Effective pH range is 4-10.

Heavy metals are removed through media adsorption technology rather than chemical precipitation. Differences in raw water quality do not matter when adsorption technology is selected for heavy metals removal.

Our research has established that suspended solids in the flow stream rather than biological growths cause the so-

called 'plugging' of granular activated carbon contactors. Backwashing activated carbon always reduces its treatment capacity because of the associated disruption of the adsorption profile. Media plugging can easily be pre-vented by removing particulate matter down to 1 micron in size upstream from the adsorption device. The entire ContamAway II™ product line utilizes this design approach.

### Principal Features

- ◆ User Friendly. Maintenance requirements are specifically identified. No guesswork necessary.
- ◆ Extended run times between maintenance procedures. Each system component is intentionally oversized to maximize service cycle.
- ◆ No chemicals required. Raw wastewater may vary considerably without any change in effluent quality.

### System Description - Summary

The ContamAway II™ product line accomplishes treatment through filtration and adsorption technologies. The first treatment vessel is called a **5 micron cartridge filter T-01 and T-02**. This unit removes suspended solids. Two units are provided to permit continuous operation while one unit is being serviced. As an alternative, both units may be operated simultaneously with the understanding that plant shut down is required for servicing. The 5 micron cartridge filter effluent is further treated by a **1 micron cartridge filter T-03** which removes suspended solids to 1 micron in size as well as free and mechanically emulsified oils. The 1-micron filter effluent is further treated by tri-media adsorption consisting of OrganoSorb™ over granular activated carbon over MetalSorb™. The above design maximizes the useful life of the tri-media adsorber, which is the single most expensive component of the treatment system. The 5-micron cartridge filter, the 1 micron cartridge filter and the tri-media adsorber must be replaced when their useful capacities have been reached.

### System Description - Complete

The ContamAway II™ product line is always fed from a sump. The use of a slotted screen intake 12" or so above the sump floor:

1. Permits an accumulation of coarse sludge within the sump
2. Prevents the introduction of coarse solids into the ContamAway II™ treatment plant

The sump will also accumulate free oils until the oil thickness becomes so great that oil enters the pump suction

inlet before the pump cut-off level is reached. The use of either an endless belt type oil skimmer or floating oil removal servicing in a timely manner will prevent this from occurring.

If the sump level gets too high, an audible alarm horn will sound simultaneous with a flashing light. A push-button silences the horn but the light continues to flash until the high liquid level condition falls below the alarm level. Alarm reset occurs automatically.

The pump used for liquid transfer is a shallow well jet pump with a 25 ft suction lift capability. If the pump detects excessive discharge pressure the pump will shut down automatically with alarm indication.

When the first treatment component, a 5 micron cartridge filter, becomes plugged, a high differential pressure switch initiates an alarm reflecting the necessity to clean the filter by changing out the plugged cartridges. This filter is greatly oversized in order to maximize the run time between servicing. Mechanically and chemically emulsified oils as well as dissolved organics and inorganics pass through this filter. By noting the totalized flow, the next servicing can be estimated.

After 5 micron cartridge filtration, the wastewater is filtered through an oversized 1 micron coalescing cartridge filter. In addition to removing suspended solids to 1 micron, the filter removes free and mechanically emulsified oils. The mega cartridge filter consists of a spirally wound polypropylene fabric tight-to-loose such that depth filtration is accomplished. Three different porosities of fabric are used with the tightest on the innermost wraps and the loosest on the outermost wraps. Polypropylene is oleophilic (oil-loving) and it is this property which achieves the removal of free and mechanically emulsified oils. As the cartridges reach their adsorptive capacity a progressively higher pressure drop develops such that the cartridge eventually becomes plugged with both suspended solids and oils. As this occurs an alarm is initiated which reflects the need for servicing. By noting the totalized flow, the next servicing can be estimated. The space above the mega cartridge is for separated free oil storage which can be discharged through the dedicated oil drain valve. The mega cartridge filters adsorb up to 15 times their weight in dispersed petroleum hydrocarbons. Chemically emulsified oils, dissolved organics, and dissolved inorganics pass through the 1-micron filter.

The tri-media adsorber consists of 1/3 OrganoSorb™, 1/3 acid washed lignite based aqueous phase granular activated carbon, and 1/3 MetalSorb™ adsorption medias. The adsorber has 10 minutes EBCT (empty bed contact time). A second tri-media adsorber can be provided in series flow in order to permit change-out of the first adsorber without taking the ContamAway unit off-line. A replacement adsorber then becomes the lag unit. Lignite based carbon is used because it adsorbs a wider range of molecular organics than bituminous based carbons. Acid washed GAC adsorbs far more organics and heavy metals than non-acid washed. The adsorber also removes chemically emulsified oils, TOC, BOD, TOX, VOC, and SVOC compounds. Because particles to 1 micron are removed upstream from the adsorbers, no backwashing of the carbon is ever necessary. If COCs (contaminants of concern) include anions such as cyanides, hexavalent chromium, selenium, and arsenic, their removal may be accomplished using a polishing AnSorb™ adsorber.

Of significance to routine operation, no chemicals are required to achieve the effective removal of a broad spectrum of contaminants. Since raw characteristics can and do change, the absence of chemical addition translates into simple, reliable, and easy operation.

#### **Vapor Emission Control**

The ContamAway II system is entirely enclosed which eliminates all vapor emissions to the atmosphere. Even the skid drain piping is extended well below the minimum sump liquid level to further prevent any possibility of uncontrolled vapor emissions to the environment. No air monitoring is therefore necessary. The alarm conditions call out the required maintenance procedure whereas the flow meter enables the operator to accurately predict the next maintenance requirement. Convenient sampling of the raw and treated water flows is provided.

All equipment is skid mounted. The ContamAway II™ is factory piped, wired, and tested prior to shipment. Site installation consists of terminal connections and power feed only.

The ContamAway II™ product has been equipped with several instruments for ease of operation. These instruments include visual and audible alarms that identify various maintenance or operational requirements as they occur as shown in Table 1.

#### **Quality Control**

The ContamAway II™ is skid mounted, factory assembled, prepiped, prewired, and fully tested prior to shipment.

Condition	Initiates	Requirement
Sump Switch LS-02 <b>High Liquid Level*</b>	Visual flashing lamp alarm, audible horn alarm, and red status light. <b>System operation continues.</b> Actuating red alarm acknowledge push-button will silence the audible horn alarm but the other two lights will remain on. After the high liquid level falls below the alarm level the visual flashing lamp and red status light both turn off and the visual and audible alarms automatically reset.	Temporarily reduce wastewater discharge rate
Feed Pump P-01 <b>High Pressure*</b>	Visual flashing lamp alarm, audible horn alarm, and red status light. <b>System operation is automatically stopped.</b> Actuating red alarm acknowledge push-button will silence the audible horn alarm but the other two lights will remain on. After the high pressure condition has been corrected the visual flashing lamp and red status light both turn off when the blue master reset alarm push-button is actuated.	Plugged piping
5 Micron Cartridge Filters T-01 & T-02 <b>High Differential Pressure*</b>	Visual flashing lamp alarm, audible horn alarm, and red status light. <b>System operation is automatically stopped.</b> Actuating red alarm acknowledge push-button will silence the audible horn alarm but the other two lights will remain on. After the high differential pressure condition has been corrected the visual flashing lamp and red status light both turn off when the blue master reset alarm push-button is actuated.	Replace 5 micron filter cartridges
1 Micron Cartridge Filter T-03 <b>High Differential Pressure*</b>	Visual flashing lamp alarm, audible horn alarm, and red status light. <b>System operation is automatically stopped.</b> Actuating red alarm acknowledge push-button will silence the audible horn alarm but the other two lights will remain on. After the high pressure condition has been corrected the visual flashing lamp and red status light both turn off when the blue master reset alarm push-button is actuated.	Replace 1 micron filter cartridges
Dual Media Adsorber T-04 <b>High Adsorber Pressure*</b>	Visual flashing lamp alarm, audible horn alarm, and red status light. <b>System operation is automatically stopped.</b> Actuating red alarm acknowledge push-button will silence the audible horn alarm but the other two lights will remain on. After the high differential pressure condition has been corrected the visual flashing lamp and red status light both turn off when the blue master reset alarm push-button is actuated.	Plugged adsorber or downstream piping

*\*Indicates improper condition*

The following table shows additional ContamAway II™ design combinations that have been engineered for closely related applications. For additional information on these designs contact **WaterSmart Environmental**.

PROCESS	DWG. NO.
Two GAC dual media adsorbers in series or parallel flow with 20 minutes EBCT	S-1730, S-1731, S-1732, S-1733, S-1734
One GAC dual media adsorber and one anion adsorber in series flow	S-1740, S-1741, S-1742, S-1743, S-1744
Two GAC dual media adsorbers in series or parallel flow with 20 min EBCT followed by one anion adsorber	S-1760, S-1761, S-1762, S-1763, S-1764, S-1765

#### Lease/Purchase

The ContamAway II System is available on a purchase or lease/rental basis as follows:

LEASE/RENTAL OPTION	
MODEL	MONTHLY CHARGE
CA2-05	\$2,643.00
CA2-15	\$4,174.00
CA2-25	\$5,438.00
CA2-50	\$8,448.00
CA2-100	\$16,944.00

**Lease/Rental Terms:**

- ◆ Availability: Four (4) weeks after receipt of order (ARO) or after receipt of approved submittals (ARAS), whichever applies.
- ◆ Three (3) month minimum charge payable with transmittal of fully executed lease/rental agreement.
- ◆ 50% of initial twelve (12) months lease/rental is applicable to purchase price any time during the lease period.
- ◆ Final equipment decontamination, if required, is the responsibility of user.

<b>PURCHASE OPTION – DEALER PRICES</b>					
<b>MODEL</b>	<b>CA2- 05</b>	<b>CA2-15</b>	<b>CA2- 25</b>	<b>CA2-50</b>	<b>CA2-100</b>
Unit Price - Effective 1/1/04	\$52,660.00	\$82,750.00	\$111,550.00	\$130,840.00	\$228,860.00
Replacement 5 micron filter cartridge set (number in set)	166 (8)	166.00 (8)	166.00 (8)	322.00 (16)	644.00 (32)
Replacement 1 micron cartridge filter set (number in set)	650.00 (1)	1,950.00 (3)	2,600.00 (4)	5,200.00 (8)	10,400.00 (16)
Replacement tri-media adsorber set (number in set)	3,160.00 (1)	4,675.00 (1)	9,063.00 (1)	18,125.00 (2)	35,000.00 (2)
Equipment Layout Drawing No.	S-1711	S-1711	S-1712	S-1712	S-1713
Process Flow Schematic Dwg No.	S-1710	S-1710	S-1710	S-1710	S-1710

**Selling Terms:**

- ◆ 50% of contract amount with purchase order;
- ◆ 40% of contract amount upon completion of manufacturing and prior to shipment;
- ◆ 10% of contract amount net 30 days from shipment date.
- ◆ Availability: Four (4) weeks after receipt of order (ARO) or after receipt of approved submittals (ARAS), whichever applies.

**FOR BOTH ABOVE OPTIONS**

- ◆ Price includes Operation & Maintenance manuals.
- ◆ Plant start-up and operator training services are available at the rate of \$660.00/day (one factory trained representative) plus portal to portal expenses.
- ◆ No taxes, permit fees, chemicals, spare parts, site labor, or technical services are included.
- ◆ All freight charges are at customer's account. Customer to be responsible for equipment loading and unloading at project location.



# Equipment and Performance Specifications

6001

## Product: ContamAway II™ High Performance Aqueous Waste Treatment System

Par. \_\_\_\_\_ Wastewater Treatment (and Water Reuse) System

The system to be furnished must be capable of treating the wastewaters generated by maintenance type cleaning operations without requiring chemical addition. **Contaminant removal is to be accomplished using filtration and adsorption technologies only in order to minimize operator skill requirements without compromising treatment performance. Treatment systems that require chemical feed addition are not acceptable and will not be considered.** Contaminants to be removed include free and emulsified petroleum hydrocarbons (oils, grease, and fuels), heavy metals, suspended solids, cleaning fluids, anti-freeze coolants, and detergents.

The unit shall be equipped with suspended solids removal components in order to accommodate heavy solids loadings. All components shall be generously oversized in order to maximize the run time between maintenance procedures. As a minimum, treatment shall consist of two stages of suspended solids removal followed by mechanically emulsified oil removal followed by three stages of dissolved organics and heavy metals removal by adsorption. A total of 10 minutes of empty bed contact time (EBCT) shall be provided. (A second in-service adsorber can be furnished to increase the EBCT to 30 minutes at a cost adder.) All equipment shall be factory piped and wired on a common epoxy painted steel skid. The com-

pleted unit shall be tested for leaks and for functional integrity prior to shipment.

A raw water feed pump with liquid level controls shall be provided in order to transfer wastewater from the collection sump. Power availability at the site is \_\_\_\_\_.

Operation of the plant shall be entirely automatic with alarm indication of routine maintenance requirements. The treatment capacity of the plant shall be \_\_\_\_\_ gpm.

The treatment system shall be installed in a concrete vault as shown on the plans.

The treatment system shall be enclosed in an epoxy painted 1/4" A-36 carbon steel or concrete vault as shown on the plans

A representative of the factory shall participate in the start-up of the equipment and shall provide two hours of operator training. Lastly, the unit shall be tested to establish proof of performance. An independent testing laboratory shall do the sample testing. A test procedure shall be furnished by the vendor for consideration by the contracting officer.

The treatment system shall reduce contaminants to the following levels:

CONTAMINANT	LEVEL
Suspended Solids	Less than one (1) mg/L (ppm)
Oil and Grease	Less than 10 mg/L (ppm) (EPA Test Method 413.1)
BOD	Less than 10 mg/L (ppm)
COD	Less than 10 mg/L (ppm)
TOC	Less than 10 mg/L (ppm)
Heavy Metals, Total	Less than 1 mg/L (ppm)

### Quality Assurance

1. Installation: Provide a qualified manufacturer's representative to supervise work related to equipment installation, check out, customer training and startup.
2. Training: Provide technical representative to train Owner's Maintenance personnel in operation and maintenance of specified equipment.

### Suppliers Qualifications

1. Supplier shall have been regularly engaged in the design and supply of the type of equipment specified herein, for a period of not less than five years. Assembled components such as motors, pumps, electrical devices, etc., shall be the standard products of qualified manufacturers. All similar items shall be the products of one manufacturer. The equipment offered shall be the latest standard product, modified as necessary to meet the requirements of the specification, of a type that has

been commercially available and in satisfactory use for at least five years.

2. The equipment specified herein is based on the water purification equipment as supplied by WaterSmart Environmental, Inc. of Shawnee Mission, Kansas or engineer approved equal.
3. All contractors bidding non approved equipment shall submit to the engineer 14 days prior to bidding the following information for approved equal status:
  - A. Detailed description of the sequence of the operation of the proposed system.
  - B. Equipment general layout drawings of the proposed system.
  - C. List (minimum of 5 sites) of water purification equipment installations similar in usage where the proposed equipment by the supplier has been in service, including the duration of service.
  - D. Provide name of contact person at each installation location that is familiar with the operation and maintenance of the water purification equipment.
4. Based on the information supplied and discussions with contact persons named, the engineer will determine the acceptability of the proposed supplier and the equipment.

#### **Deviations From These Specifications**

1. No deviations from these specifications will be allowed unless approved by the Engineer in writing prior to bid closing as specified herein. All equipment and equipment functions must be built and designed to these specifications.
2. Regardless of the Engineer's approval for any deviations and/or changes, the Contractor is solely responsible for the performance of the supplied equipment as per these specifications.
3. The Engineer may permit variations from the requirements of these specifications provided that in his/her opinion such proposed equipment fully meets and/or exceeds these specifications and the specified

performance and is in every way adequate for the intended use. All such variations proposed by the Contractor shall be called to the attention of the Engineer in writing 14 days prior to the bid opening and shall be made only if approved in writing.

4. Certain design limitations, tests, etc. are herein specified as a partial check on the adequacy of design, fabrication, and materials. These requirements do not cover all features necessary to insure satisfactory and approved operation of the equipment. Conformity of these requirements shall in no way supersede the general requirements as to satisfactory and efficient operation of the equipment.

#### **System Performance**

1. The supplier is responsible to design, engineer, manufacture, supply, and start-up the water purification equipment to satisfactorily treat and clean the wastewater. Representatives of the owner will gauge satisfactory performance.
2. The supplier is solely responsible for the equipment performance. Should the equipment not perform as per specification requirements, the supplier shall modify, and/or alter the equipment supplied at his own expense until the performance is satisfactory. The engineer shall approve all such changes.

#### **Warranty**

1. Warranty work specified herein is for one (1) year from substantial completion against defects in materials and in labor and workmanship
2. Defects shall include, but not be limited to:
  - A. Operation: Noisy, rough or substandard operation.
  - B. Parts: Loose, damaged and missing parts.
  - C. Finish: Abnormal deterioration
3. The supplier guarantees that he is familiar with the cleaning requirements and that the system shall be built to accommodate such.



# Installation, Operation, and Maintenance Instructions

6001

## Product: ContamAway II™ High Performance Aqueous Waste Treatment System

### Installation

- ◆ Set skid mounted treatment system on concrete equipment pad. Refer to WSE drawing 3178-PR1 for operating weight. Refer to drawing 3178-PR2 for equipment size, or to submittal drawings, if applicable.
- ◆ Install sump strainer/check valve assembly, piping, and liquid level switches (provided). Provide and then install connecting piping between sump and treatment system taking care to eliminate all leaks. Treatment system feed pump will not maintain a prime if leaks exist in the feed pump suction piping.
- ◆ Treatment system skid is equipped with a one inch diameter drain which must be piped to the feed sump.
- ◆ Connect discharge piping to destination tankage, outfall, or sewer. **Caution: pressure in discharge piping must not exceed 20 PSIG as the final tri-media adsorber vessel is limited to this working pressure.** Repumping of treated water will be necessary if the effluent pressure requirements exceed 20 PSIG.
- ◆ Install wide angle float switches in the sump. One float switch operates the feed pump. The other float switch initiates a high sump liquid level alarm condition. The feed pump float switch should be installed and the tether length adjusted such that the float stops the pump about 24 inches from the bottom floor. The pump should be initiated when the sump is approximately 50% full. The entire panel is equipped with status lights which indicate the levels at which the switches operate. The remaining float should have a short tether (approximately 6 inches) to initiate a high sump condition at approximately 90% of its useful capacity. Refer to Wide-angle Sump Pump Float Switch installation instructions.
- ◆ Connect power feed to the electrical control panel (provided). Refer to WSE drawing S-1710 or submittal drawings, if applicable, for required power demand requirements.

### Start-up

**Step #1:** Turn feed pump selector switch to the "off" position.

**Step #2:** Shut control panel door and rotate power disconnect switch to "on" position.

**Step #3:** The next step requires filling the sump with sufficient water to fill the treatment system (500 to 1000 gallons). Four vessels requires filling: 5 micron cartridge filters T-01 and T-02, 1 micron cartridge filter T-03, and dual media adsorber T-04. Vessels T-01, T-02, and T-03 are equipped with a manual air and vacuum release valve located on top. These valves are rotated clockwise to open and counterclockwise to close. There are some 4-5

complete revolutions from full open to full close positions. Close manual valve on T-03 and open valve on T-01 and T-02. Close manual valve (handle perpendicular to piping) between T-03 and dual media adsorber T-04.

**Step #4:** Prime feed pump by adding water to pump volute (see pump O & M manual for details).

**Step #5:** Run pump in manual mode of operation to fill treatment system. When T-01 overflows close manual valve. Now open valve on T-03. When T-02 overflows close manual valve. When T-03 overflows, close valve and stop pump.

**Step #6:** Open valve between T-03 and dual media adsorber. Run pump in manual mode for 10 minutes to fill dual media adsorber. Then stop pump. In order to achieve maximum treatment efficiency, the dual media adsorber must be saturated with water for a minimum of 24 hours. Treatment system is now ready for automatic operation. At the end of 24 hours turn feed pump to "automatic" operation.

### Operation and Maintenance

The ContamAway II™ product line is equipped with several sensors and alarm conditions to make routine servicing and trouble shooting user friendly to understand. Routine servicing consists of three (3) procedures:

- ◆ Replace 5 micron cartridge filters in vessels T-01 and T-02, when required. The cartridges are removed by closing the three (3) isolation valves, opening the vessels' air/vacuum release valve, and then opening the drain valve to drain the vessel. Remove wing nuts on vessel top to replace 5 micron cartridge filters. Replace cover, close air/vacuum release valve, and reopen isolation valves. Manually start pump to again bleed air from each vessel by opening its air/vacuum release valve. When the 5 micron cartridge filter requires replacement, a high differential pressure alarm will be initiated. System operation will automatically shut down until the cartridge filter is changed out.
- ◆ Replace 1 micron cartridge filters in vessel T-03. These filters must be replaced, as they cannot be successfully cleaned. The cartridges are removed by closing the isolation valves, opening the air/vacuum release valve, and then opening the drain valve to drain the vessel. Remove hinged cover nuts to remove 1 micron cartridge filter(s). The cartridge filters have a Tee handle. Turn the handle counterclockwise to disengage threaded fitting. Dispose of the 1 micron cartridge filters in accordance with applicable regulations. Replace cartridge filter(s), replace cover, close air/vacuum release valve, and reopen isolation valves. Manually start pump to bleed air from vessel by opening air/vacuum release valve. When the 1 micron cartridge

filter requires cleaning, a high pressure alarm will be initiated. System operation will automatically shut down until the cartridge filter is changed out.

- The tri-media adsorber must be replaced when the laboratory test results indicate that ultimate treatment capacity has been reached. Environmental influent and effluent sample valves have been provided to monitor system performance.

Specific abnormal operating conditions will initiate audible and visual alarms. If the feed pump pressure gets too high, the pump will automatically shut off. If the feed pump flow rate falls below a specific minimum, the pump will automatically shut off. The several maintenance and alarm conditions are summarized in the following table.

Condition	Initiates	Requirement
Sump Switch LS-02 <b>High Liquid Level *</b>	Visual flashing lamp alarm, audible horn alarm, and red status light. <b>System operation continues.</b> Actuating red alarm acknowledge push-button will silence the audible horn alarm but the other two lights will remain on. After the high liquid level falls below the alarm level the visual flashing lamp and red status light both turn off and the visual and audible alarms automatically reset.	Temporarily reduce wastewater discharge rate
Feed Pump P-01 <b>High Pressure*</b>	Visual flashing lamp alarm, audible horn alarm, and red status light. <b>System operation is automatically stopped.</b> Actuating red alarm acknowledge push-button will silence the audible horn alarm but the other two lights will remain on. After the high pressure condition has been corrected the visual flashing lamp and red status light both turn off when the blue master reset alarm push-button is actuated.	Plugged piping
5 Micron Cartridge Filters T-01 and T-02 <b>High Differential Pressure</b>	Visual flashing lamp alarm, audible horn alarm, and red status light. <b>System operation is automatically stopped.</b> Actuating red alarm acknowledge push-button will silence the audible horn alarm but the other two lights will remain on. After the high differential pressure condition has been corrected the visual flashing lamp and red status light both turn off when the blue master reset alarm push-button is actuated.	Replace 5 micron filter cartridges
1 Micron Cartridge Filter T-03 <b>High Differential Pressure</b>	Visual flashing lamp alarm, audible horn alarm, and red status light. <b>System operation is automatically stopped.</b> Actuating red alarm acknowledge push-button will silence the audible horn alarm but the other two lights will remain on. After the high pressure condition has been corrected the visual flashing lamp and red status light both turn off when the blue master reset alarm push-button is actuated.	Replace 1 micron filter cartridges
Tri-Media Adsorber T-04 <b>High Adsorber Pressure*</b>	Visual flashing lamp alarm, audible horn alarm, and red status light. <b>System operation is automatically stopped.</b> Actuating red alarm acknowledge push-button will silence the audible horn alarm but the other two lights will remain on. After the high differential pressure condition has been corrected the visual flashing lamp and red status light both turn off when the blue master reset alarm push-button is actuated.	Plugged adsorber or downstream piping

\*Indicates improper condition



# ContamAway II™ Maintenance Record

Procedure	Date	Flow Meter Reading	Date	Flow Meter Reading	Date	Flow Meter Reading
Change 5 Micron Cartridge						
Change 1 Micron Cartridge						
Change Tri-Media Adsorber						
Change Anion Adsorber						
Other						
Change 5 Micron Cartridge						
Change 1 Micron Cartridge						
Change Tri-Media Adsorber						
Change Anion Adsorber						
Other						



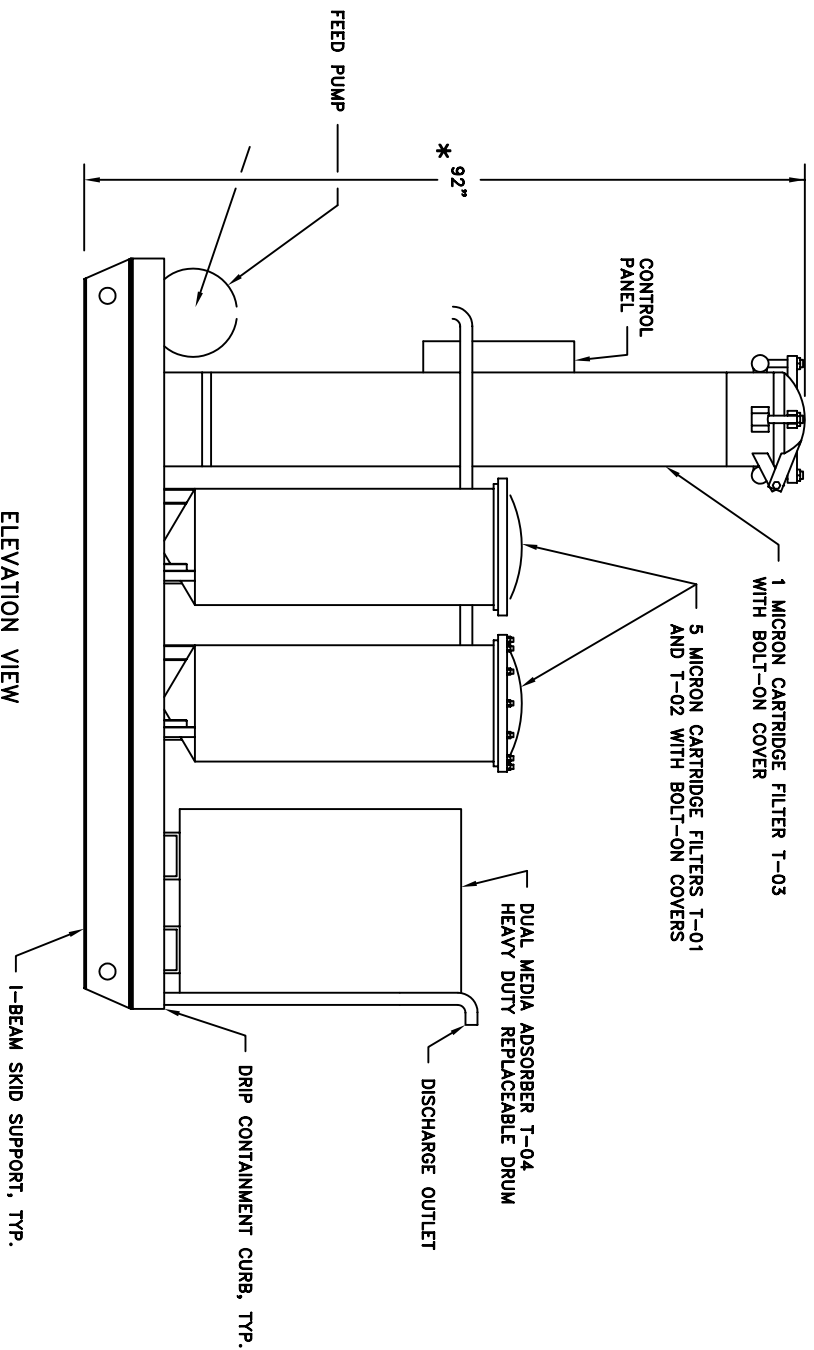
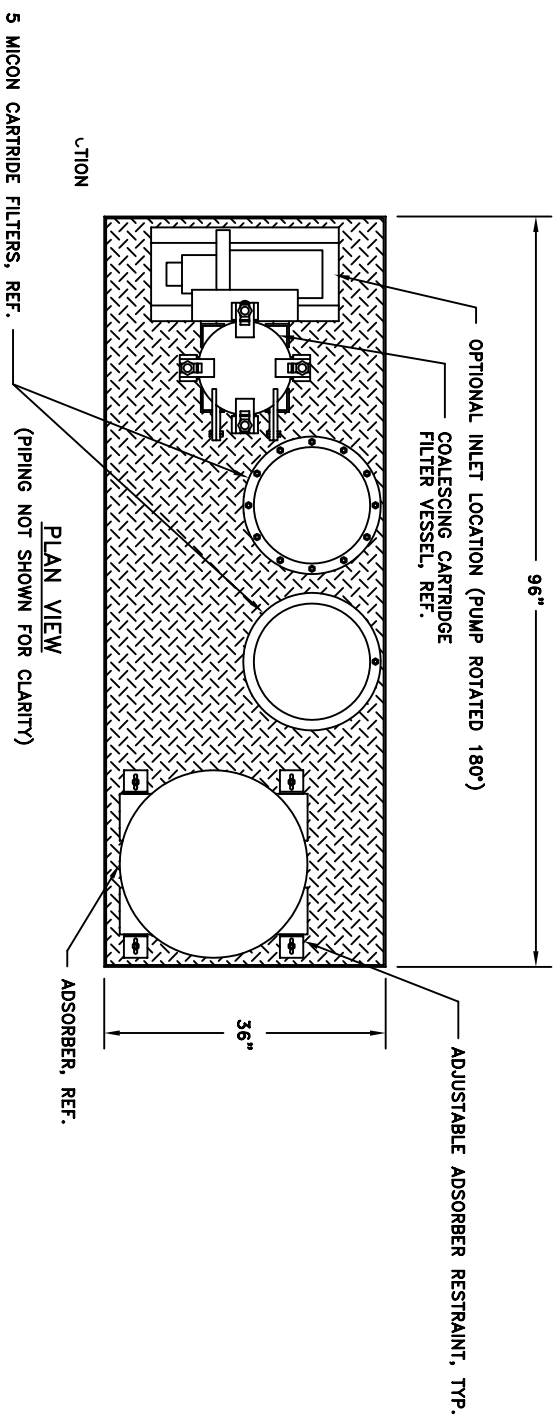

ELEVATION VIEW  
MODEL CA2-05

144" MAXIMUM HEIGHT REQUIRED

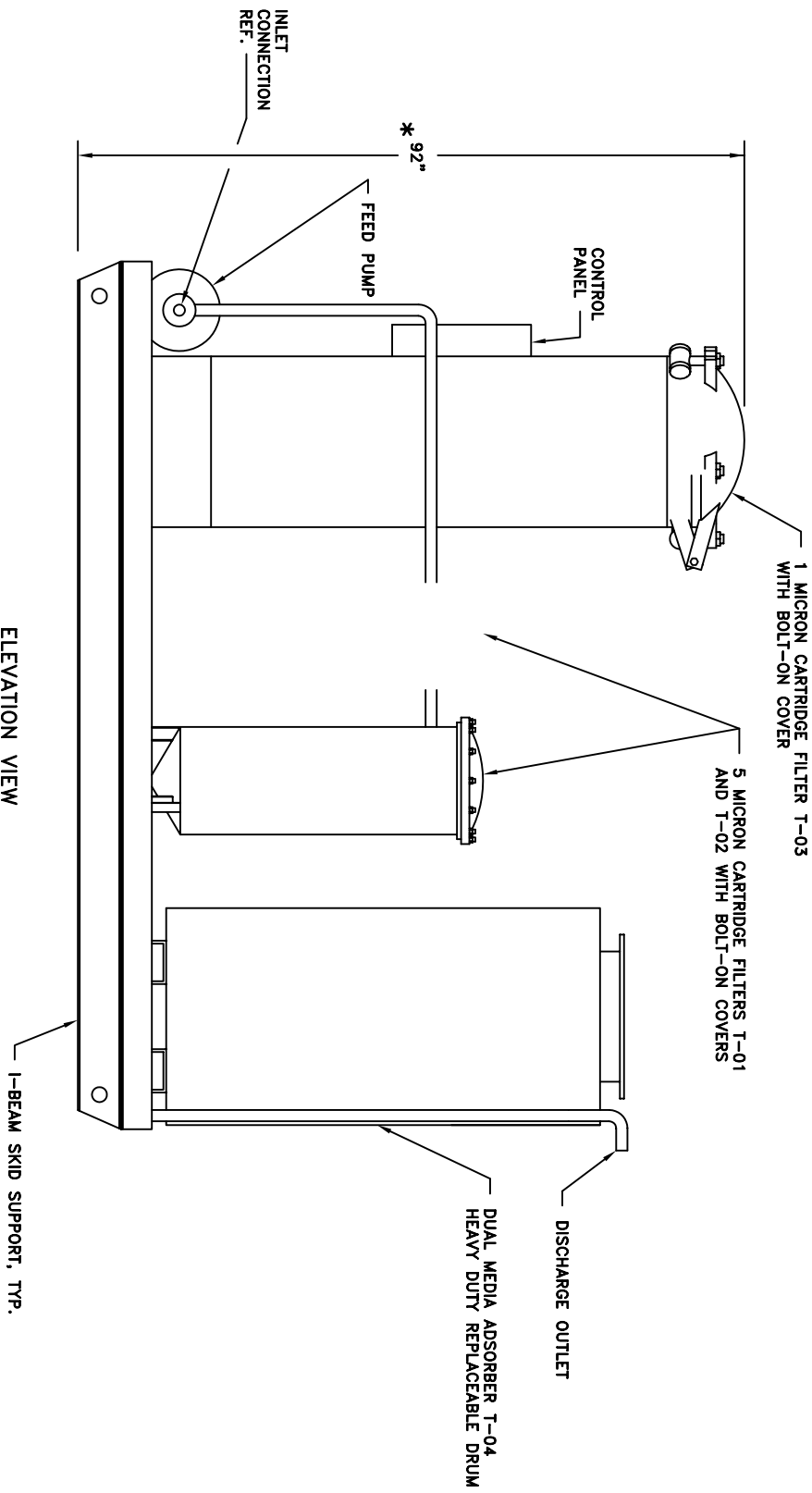
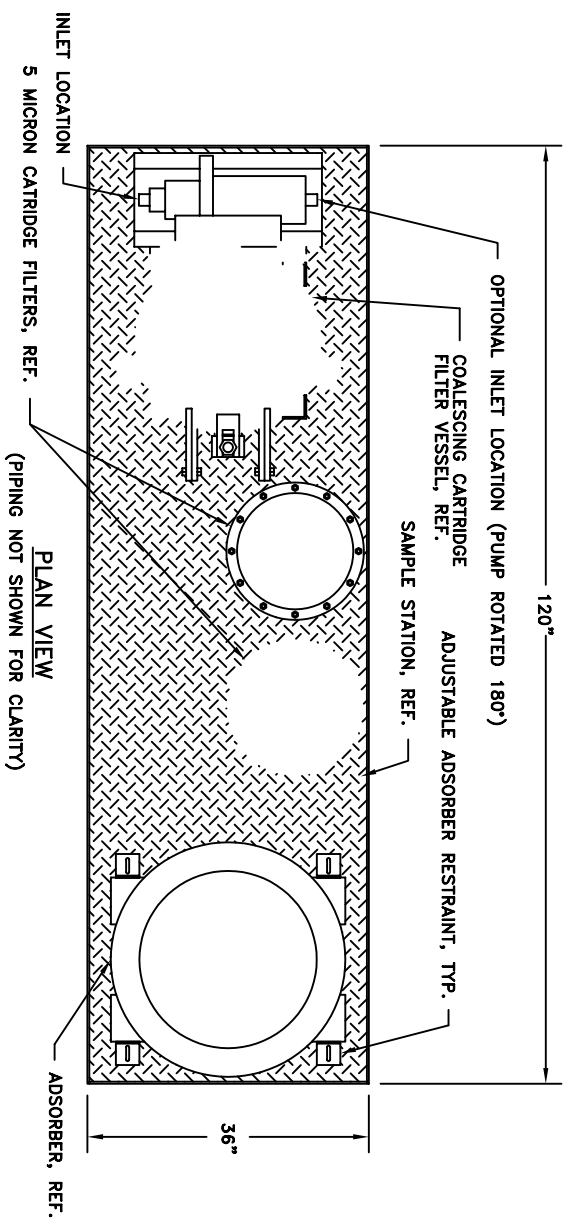

ELEVATION VIEW  
MODEL CA2-15

ContamAway II™

EQUIPMENT LAYOUT

REV.	DATE	DESCRIPTION	BY	CHK	DATE	SCALE	DRAWN	CHECKED	DATE	BY	CHK	DATE	SCALE	DRAWN	CHECKED	DATE	BY	CHK	DATE
1	5/1/96	GENERAL REVISION	BEH	CSS	12/18/95	1"=1'-0"													
DO NOT SCALE DRAWING. USE DIMENSIONS ONLY.																			

PLEASE BE ADVISED THAT THE DESIGN AND DETAIL ON THIS DRAWING ARE THE EXCLUSIVE PROPERTY OF WATERSMART ENVIRONMENTAL, INC. SAID INFORMATION IS PROPRIETARY AND MAY NOT BE USED EXCEPT IN CONNECTION WITH OUR BUSINESS. ALL INVENTION RIGHTS ARE RESERVED.

**WaterSmart Environmental, Inc.**  
Post Office Box 26346  
Shawnee Mission, Kansas 66225

108

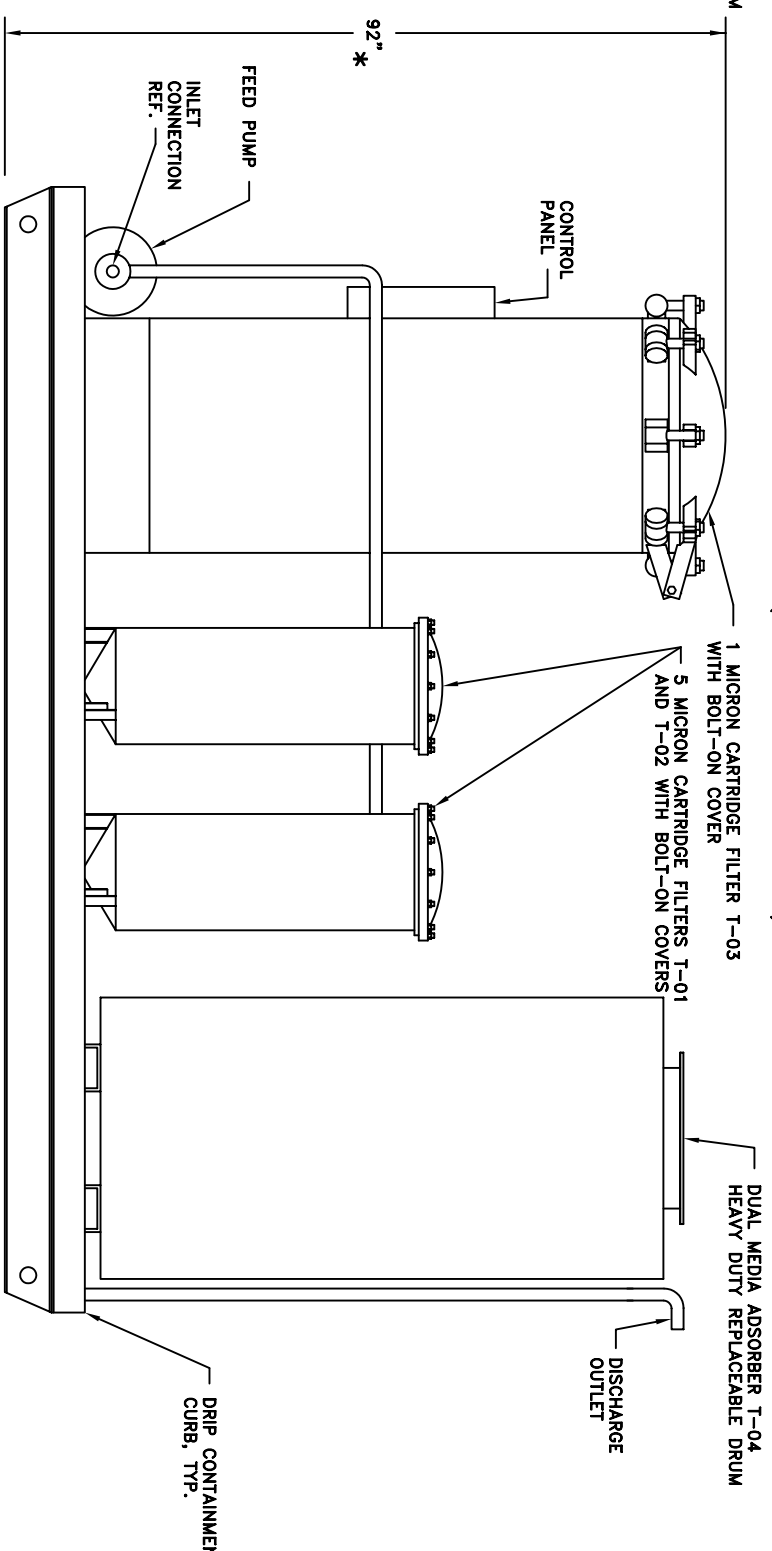
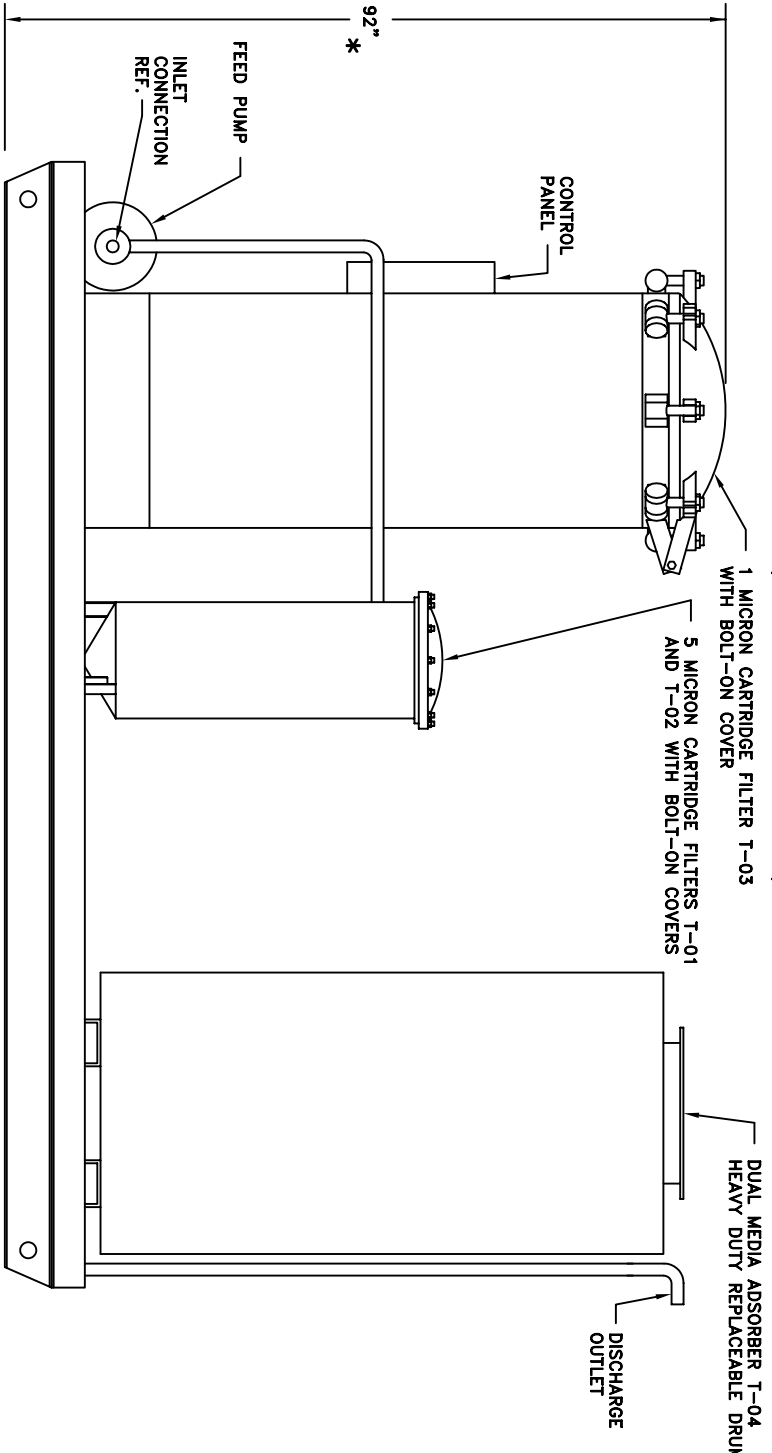
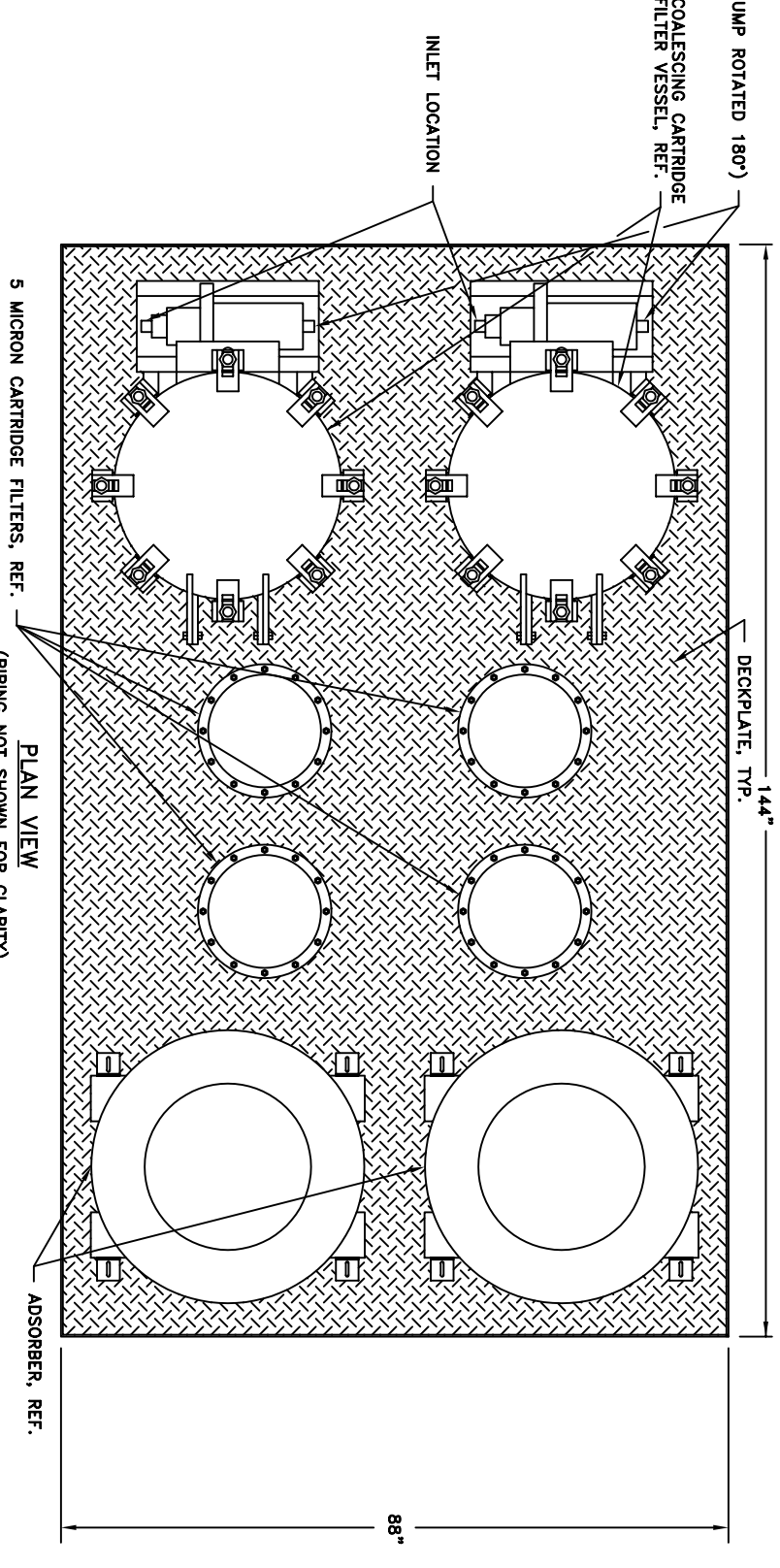

ELEVATION VIEW  
MODEL CA2-25

ELEVATION VIEW  
MODEL CA2-50

\* 144" MAXIMUM HEIGHT REQUIRED FOR CARTRIDGE FILTER CHANGE OUT

ContamAway II™

PLEASE BE ADVISED THAT THE DESIGN AND DETAIL ON THIS DRAWING ARE THE EXCLUSIVE PROPERTY OF WATERSMART ENVIRONMENTAL, INC. SAID INFORMATION IS PROPRIETARY AND MAY NOT BE USED EXCEPT IN CONNECTION WITH OUR BUSINESS. ALL INVENTION RIGHTS ARE RESERVED.

**WaterSmart Environmental, Inc.**  
Post Office Box 26346  
Shawnee Mission, Kansas 66225

EQUIPMENT LAYOUT

REV.	DATE	DESCRIPTION	BY	CHK	SCALE	DRAWN	CHECKED	DATE	DATE	DATE
1	5/1/96	GENERAL REVISION	BEH	CSS	1"=1'-0"	BEH	B.E.H.	12/18/95	12/18/95	12/18/95

DO NOT SCALE DRAWING. USE DIMENSIONS ONLY.

© 1997 WATERSMART ENVIRONMENTAL, INC. ALL RIGHTS RESERVED.

\* 162" MAXIMUM HEIGHT REQUIRED FOR CARTRIDGE FILTER CHANGE OUT

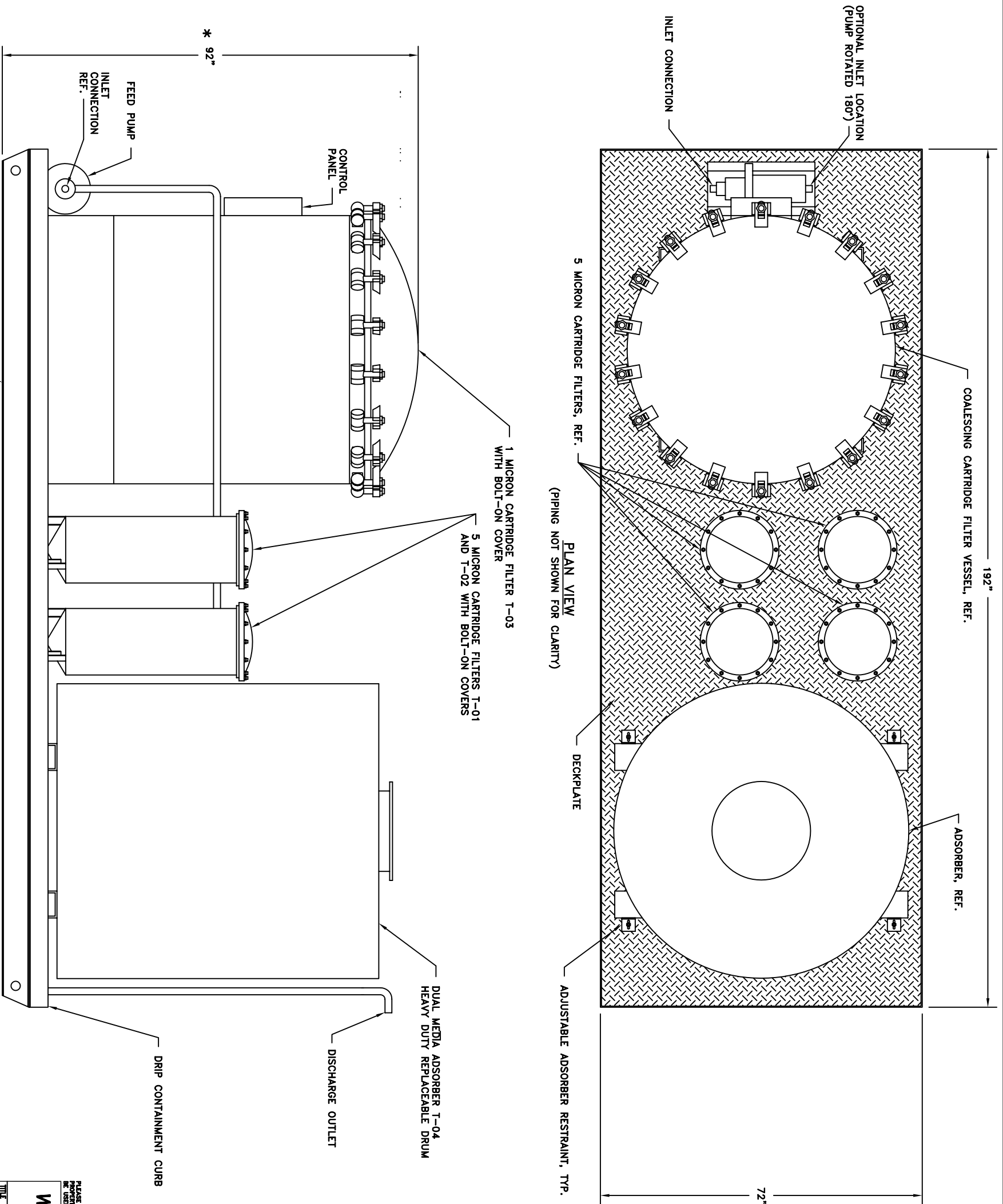

ELEVATION VIEW  
MODEL CA2-100

ContamAway II™

REV.	DATE	DESCRIPTION	BY	CHK	SCALE	DRAWN	CHECKED	DATE	BY	CHK	DATE
1	5/1/96	GENERAL REVISION	BEH	CSS	1"=1'-0"	B.E.H.	C.S.S.	12/18/95	BEH	CSS	12/18/95
DO NOT SCALE DRAWING. USE DIMENSIONS ONLY.											

TITLE  
EQUIPMENT LAYOUT

**WaterSmart Environmental, Inc.**  
Post Office Box 26346  
Shawnee Mission, Kansas 66225

PLEASE BE ADVISED THAT THE DESIGN AND DETAIL ON THIS DRAWING ARE THE EXCLUSIVE PROPERTY OF WATERSMART ENVIRONMENTAL, INC. SAID INFORMATION IS PROPRIETARY AND MAY NOT BE USED EXCEPT IN CONNECTION WITH OUR BUSINESS. ALL INVENTION RIGHTS ARE RESERVED.

© 1997 WATERSMART ENVIRONMENTAL, INC. ALL RIGHTS RESERVED.